

It Starts With Seeds

You may either collect seeds or buy them from a seed dealer. Naturally, there are advantages and disadvantages to both. If you need a small quantity of seeds or don't have the time or resources to spend collecting your own, purchasing from a seed dealer may be appropriate for you. Seeds for all commercial tree species in the Pacific Northwest are available from dealers, and so are most native species not usually grown in nurseries, including subalpine fir, whitebark pine, and pacific yew (see Appendix 6.7). If you purchase seeds and plan on storing them, follow instructions provided in Section 2.1.2 (Storing Seeds).

Collecting seeds may be appropriate if you want seeds from a specific location or from specific trees. Just like people, trees of a particular species come in different shapes and sizes. Remember that seedlings will usually look like their mother. Therefore, if you're interested in timber trees, don't collect from forked, crooked, or limby trees. Instead, look for trees that are tall, straight, and have clear boles. If you can't find suitable trees to collect seeds from in your locale, seeds may be transferred safely from certain elevations and areas to other elevations and

areas. Information on seed transfer can be obtained from your local state forester, university extension agent, or Natural Resource Conservation Service (NRCS) representative.

If you plan on purchasing seeds, make sure the seed source is suitable for your planting area. It's a good idea to ask the seed dealer which seed sources of a particular species they have in stock, rather than specify which source you're looking for. Some unscrupulous dealers always seem to have whatever you need if they want to make a sale badly enough. To find reputable seed dealers, you may wish to call some local nurseries.

You may have to collect seeds of the more uncommon or unusual species because dealers may not have them in

stock. If you need a large quantity of seeds, the cost of prepared seeds from a dealer can be prohibitive. Remember, it takes appreciable time to track cone development, harvest cones, and clean seeds. If you've decided to collect your own seeds, here's the best way to do it.

2.1 Collecting Cones

The following section will deal with conifers. Seed collection and processing for other native plants can be found in *Seeds of Woody Plants in the United States* or similar publications (see Appendix 6.6)

Cones are a cyclic crop. Heavy crops appear over a wide area every few years, depending on species (Table 2.1; Appendix 6.1). Other years, crops are

TABLE 2.1

Four common conifers of Idaho, Oregon, and Washington and the years between good cone crops. See Appendix 6.1 for more species.

Common name	Scientific name	Cone cycle (years)
Grand fir	<i>Abies grandis</i>	2-3
Colorado (blue) spruce	<i>Picea pungens</i>	1-3
Ponderosa pine	<i>Pinus ponderosa</i>	2-5
Rocky Mt. Douglas-fir	<i>Pseudotsuga menziesii</i> var. <i>glauca</i>	2-11

Source: Schopmeyer, C.S. 1974. *Seeds of Woody Plants in the United States*. Agricultural Handbook 450. Washington, D.C.: USDA Forest Service. 883 p. (see Appendix 6.6).

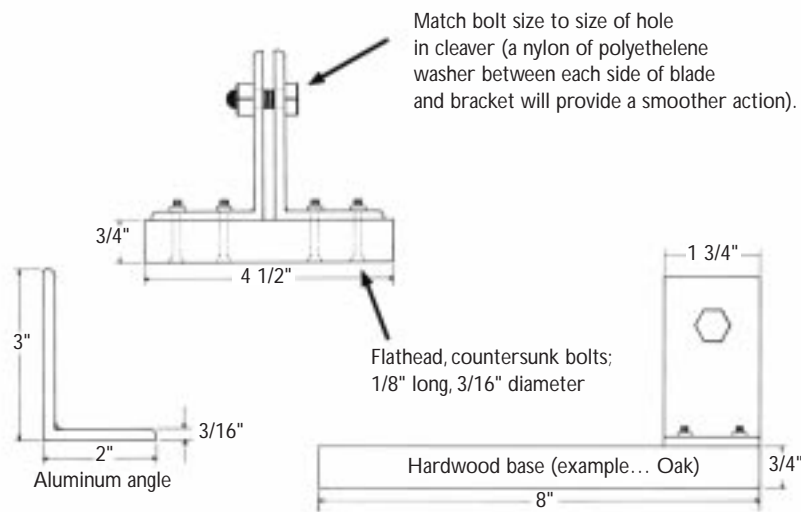
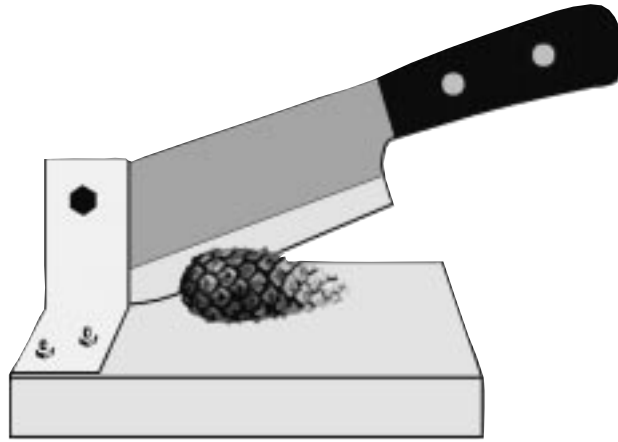

FIGURE 2.1

A cone cutter is useful for seeing how many good seeds are inside a cone (top). You can make your own using this schematic (bottom).

Source: Wilson, B.C. 1968. A cutter for sampling cone quality. *Tree Planters' Notes* 19(2): 8-9.

TABLE 2.2

Seeds per bushel of cones for four common conifers of Idaho, Oregon, and Washington. See Appendix 6.1 for more species.

<i>Common name</i>	<i>Ounces of seeds per bushel of cones</i>	<i>Number of seeds per bushel of cones</i>
Grand fir	24-32	28,500-38,000
Colorado (blue) spruce	12-20	79,500-132,500
Ponderosa pine	9-32	6,750-24,000
Rocky Mt. Douglas-fir	8-13	22,000-35,750

Source: Schopmeyer, C.S. 1974. Seeds of Woody Plants in the United States. Agricultural Handbook 450. Washington, D.C.: USDA Forest Service. 883 p. (see Appendix 6.6).

light or a complete failure since insects concentrate on what few cones are produced. Even when cones are available, the cone-picking season only lasts a few weeks in any locality. Generally, cones at lower elevations are ready first, usually around mid-August; ripening gradually moves northward and to higher elevations. Start checking potential trees around June 1 at low elevations or July 1 for higher elevations or more northerly latitudes.

For the novice, the trick is to harvest cones when seeds are mature, but before the cones dry sufficiently to flair open and release seeds. Usually, there's a change in cone color from green or purple to yellowish-green to tan as the cone dries. This change occurs gradually and is not a perfect guide to seed maturity, and often seeds are mature before the cone changes color. To really tell if seeds are mature, you'll need to cut into the cone

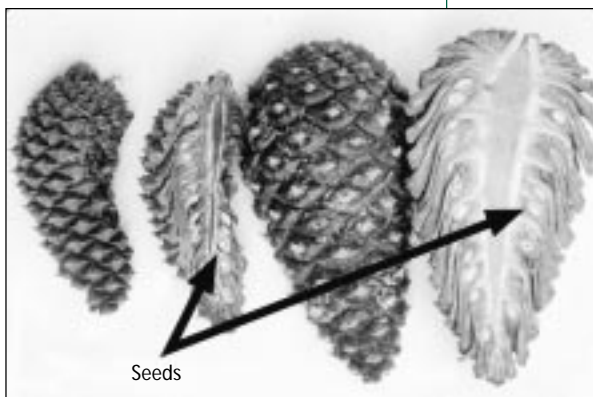

FIGURE 2.3
Cross-sections of pine cones.

and check. See Figure 2.1 for details on constructing a cone cutter.

Cutting a cone through the middle lengthwise will expose seeds of Douglas-fir, pine, hemlock, spruce, and larch for inspection (Figures 2.2 & 2.3). Cones of true firs (noble fir, grand fir, and others) are cut a little different; slice the cones lengthwise about 1/2 inch to one

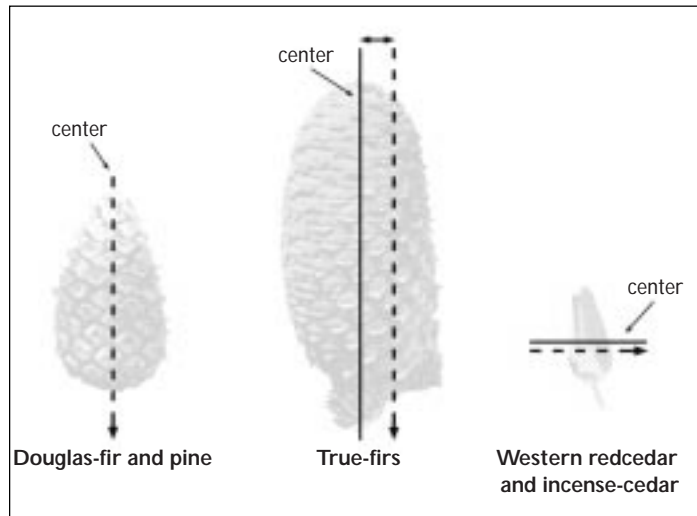

FIGURE 2.2
To check for filled seeds, cut cones of Douglas-fir, pine, hemlock, and spruce through the middle lengthwise to check for seeds (left). Cut cones of true firs lengthwise, but about 1/2 inch to one side of the cone's core (middle) and cones of western redcedar and incense-cedar widthwise just below the center of the cone (right).

side of the cone's core to ensure cutting through seeds. For western redcedar and incense-cedar, cut the cone width wise just below the center of the cone. Mature seeds have embryos that fill 90% or more of the embryo cavity, and the material around the embryo is whitish and firm with texture like coconut (Figure 2.4). Cones can be

harvested earlier, when embryos fill 75 to 90% of the cavity, but then you'll have to after-ripen the cones for 2 to 6 weeks (described below). If at least 50% of exposed seed cavities contain mature embryos, the cones are highly productive and would qualify for commercial harvest. Collecting cones with fewer seeds is justified for your own use, especially if cones are in short supply. How many cones will you need to collect? Well, it depends mostly on the species you wish to grow. The amount of seeds possible from cones is provided in Table 2.2 and Appendix 6.1.

There are several ways to collect cones, but regardless of the method, it's always a good idea to pick cones from

the upper third of the tree. Seeds from cones in the upper crown are usually the most vigorous. Collections from standing trees require special climbing gear, can be dangerous, and are best left to experienced, professional pickers. However, this method allows you to maintain desirable trees for future cone harvests. An easy way to collect cones is to schedule timber harvesting with cone ripening and simply pick cones off fallen trees; avoid picking damaged cones. You may also gather cones from the forest floor after squirrels cut them, or rob

squirrel caches, but be careful—often squirrel cache cones are moldy and the seeds are immature.

Put your cones in burlap or nylon screen sacks. Sacks should only be half full to allow for cone expansion during drying. Avoid contaminating your cones with needles, branches, and dirt which could introduce mold. Never toss or drop a bag of cones; lower it from the tree on a rope. Label each sack immediately with species, elevation, collection location, date, and any other pertinent information. Store sacks on open racks in dry, well-ventilated shelters, like open-sided sheds or well-ventilated barn lofts. You may also hang sacks from rafters. Either way, sacks should be separated to permit good air circulation. Stored this way, cones will dry gradually with a minimum of overheating and mold damage. Check cones often and inspect them for mold. If mold is present, rearrange sacks to improve air circulation. If you picked cones with mature seeds, cones should dry satisfactorily in a few days, depending on the weather. If you picked green cones, it may take a few weeks or months for seeds to finally mature.

Two species, knobcone pine and lodgepole pine, have cones that require heating before they will open. Here's an easy way to open them. Put cones into a burlap bag and immerse the bag into

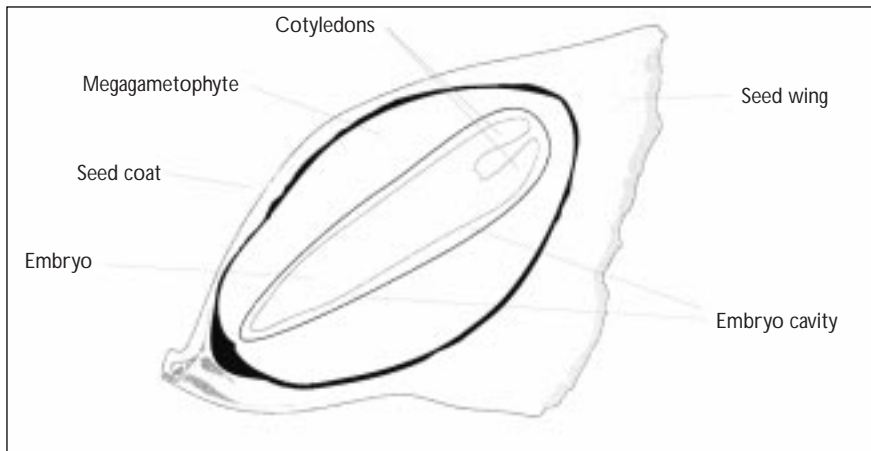
**FIGURE 2.4**

Cross-section of a mature seed. Both the embryo and megagametophyte (storage tissue) should be white and firm like coconut. The embryo should fill at least 90% of the cavity.

very hot water (about 180°F) for 30 seconds to one minute. Remove the bag, dump the cones onto a screen-bottomed tray, and place them in a warm location. The hot water softens the resins that keep the cones closed. As the cones dry, the scales pull open and you can extract the seeds.

2.1.1 Seed Extraction and Cleaning

The first step in cleaning seeds is to remove them from the cone. You can extract small quantities of seeds and clean them reasonably well at home with simple, low-cost equipment. As cones dry, the scales open and winged seeds fall out. Properly stored cones will partially open inside the sacks, and some seeds will fall out. However, to

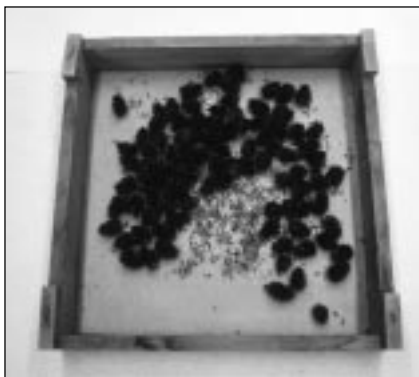
**FIGURE 2.5**

A simple window screen-bottomed box allows cones to dry without losing seeds. Put no more than one seedlot and identification label per box. Wood spacers on the corners allow boxes to be stacked for more efficient use of space while still allowing good air circulation.

remove all the seeds, cones may need further drying. Cones will dry best if placed in screen-bottomed trays (Figure 2.5), located in warm (not hot!) areas with excellent air circula-

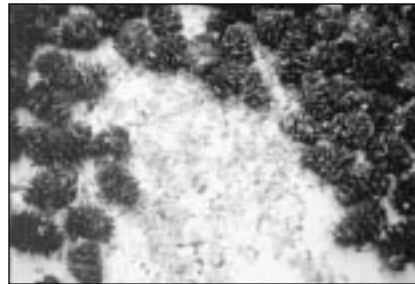
**FIGURE 2.6**

Dried cones ready to have seeds removed. Note that many seeds have already fallen from the cones.

tion. Small fans accelerate drying. If you have just a few cones, you may put them in a paper sack instead, but leave the top open. When most seeds fall out with a little gentle tapping, the cones have opened sufficiently (Figure 2.6). True fir cones will just fall apart.

The next step is cleaning seeds from cones and other debris, which is done with a combination of screening and air separation. Shake seeds and cone parts over a coarse screen (hardware cloth) attached to the bottom of a wooden box (Figure 2.7). Dislodged seeds and smaller impurities fall through the screen, leaving the spent cones and larger debris on the screen. Screen mesh size will vary with species, but 1/4- to 1/2-inch mesh

works well for Douglas-fir, while a 3/8- to 5/8-inch mesh is necessary for larger true fir seeds. Extracted, winged seeds will be mixed with pitch globules, needles, wings and small pieces of cone. Repeat the screening process with a mesh size that retains seeds but allows the smallest debris to pass through (Figure 2.8). You're then left with seeds and seed-sized debris.

The next step is de-winging. Wings are removed by filling a burlap or cloth sack 1/4 full, tying or folding it shut, and gently kneading the seeds by squeezing and rubbing from outside the sack (Figure 2.9). Friction between seeds and between seeds and burlap will detach wings. Remember to knead slowly and gently since too much friction might damage seeds. This process requires only a few minutes. With true firs, too much friction releases sticky resin from the seeds, resulting in a gummy mess which hampers further processing. A few species, like incense-cedar, have very tight wings that should be left on the seeds. Repeat the screening process again with a mesh size that retains seeds but allows the smallest debris to pass through.

Your last step is fanning or winnowing, which separates detached wings, hollow seeds, and seed-sized impurities from good seeds. The most efficient, high-tech, small scale method is with an agricultural seed cleaning or fanning mill, but these machines require careful adjustment for each species to prevent retaining too many impurities or blowing away too many sound (full) seeds. Conversely, the most primitive method is winnowing on a windy day. Pass the seeds back and forth several times by pouring them slowly from one container to another. Lighter chaff will blow away from heavier seeds. Cupping seeds in your hands and blowing them will also work. A compromise between both methods is winnowing in front of a fan. When seeds are poured slowly in front of a small electric fan, they separate according to weight from the base of the fan (Figure 2.10). Most heavy, sound seeds will come to rest near the base of the fan, and hollow seeds, wings, and lighter impurities will

tend to blow farther away. Moving from the fan outward, periodically collect a small sample of seeds and cut them in half to check for soundness (Figure 2.11). This way you can determine where the hollow seeds are and discard them. True fir seeds are more difficult to separate than other conifer seeds, and all species will probably require several successive separations to obtain a desired degree of seed purity. A good target for most species is 90% or more sound seeds.

2.1.2 Storing Seeds

Seeds need to be stored at relatively low moisture contents. Once seeds are clean, air-dry them in shallow trays for 2 to 4 weeks before storage to reduce the moisture content. Stir them once a week or so to prevent uneven drying. Put your seeds into an airtight container and label it well (Figure 2.12). The most successful way to store seeds is to keep them frozen (0 to 5°F) because storing at room temperature quickly reduces viability. Seeds may survive 10 or more years when freezer stored. For temporary storage (a few



weeks), store seeds in your refrigerator in an airtight container (lower than 40°F).

2.2 Seed Pre-treatments

Most seeds from the Pacific Northwest have evolved with a mechanism commonly called “dormancy” that keeps them from sprouting (germinating) the fall they’re dispersed from cones. Dormant seeds require a moist, cold period before they grow, and in the forest, this happens naturally during winter. For some species, the required cold period is a few days or weeks while some species may require months. This moist, cold period has traditionally been called “stratification,” an old forestry term first used in the 1600’s. The technique originally involved alternated layers of soil and seeds in a barrel, allowing these “strata” to overwinter. The combination of cold and moisture allowed metabolic changes to occur within the seeds, resulting in germination the following spring. For most species, we can now use some shortcuts.



FIGURE 2.7

Left photo: A simple wooden box with a screened bottom and fitted with a wooden cover can be used to separate cones and seeds. *Right photo:* When shaken, seeds and small impurities fall through the screen on the bottom of the box.

2.2.1 Naked Stratification

This method is best for larger quantities of seeds (more than a handful or two). Start by putting seeds into a bridal mesh or cheesecloth bag. A square piece of mesh, with seeds placed in the center, can be tied to form a crude bag (Figure 2.13). Don’t put more than a half pound of seeds per bag. Label it. Place the bag into a bucket and allow water to run through it for 48 hours. This allows seeds to absorb sufficient water to start metabolic processes necessary for germination, and running water removes fungal spores. After soaking, allow the bag to drip dry for a minute or so and suspend it within a plastic bag (Figure 2.14). Hang the bag in your refrigerator for the required time (Table 2.3; Appendix 6.1). Check it often for mold. If mold is present, gently rinse the seeds in running water and rehang in the refrigerator.

Damping-off

Sprouting seeds are very susceptible to diseases. Nursery managers generally refer to most of the diseases that infect very young seedlings as “damping-off,” and damping-off can be caused by fungi, chemicals, or even high-temperatures. When fungi cause damping-off, seedlings usually tip-over right at the soil surface and have dark, discolored roots (Figure 2.17). Generally, when seedlings damp-off because of chemical damage or heat injury, the root remains white. Damping-off is most serious on seeds with low germination speed, seeds germinating during periods of cold and wet weather, and when seedbeds are over watered. Damping-off can be minimized by using clean seeds and well-drained soil. If damping-off is particularly bad, refrain from using any nitrogen fertilizer as this worsens disease. Remove dead and dying seedlings immediately to help prevent infection of other seedlings; don’t leave them in a pile where diseases may build-up and infect your remaining seedlings—either burn them or bury them.



FIGURE 2.8
To separate seeds and smaller impurities, use a screen that retains seeds but allows debris to pass through.



FIGURE 2.9
An easy way to de-wing seeds is to put them in a cloth bag and gently knead the bag and seeds.

and refrigerate the required time (Table 2.3; Appendix 6.1). Check occasionally to ensure seeds are moist and not moldy. If they're moldy, remove the sandwich. Rinse seeds under cool, running tap water. Wash out the plastic bag with warm water and soap. Spread seeds onto a new stack of moistened paper towels, put the sandwich back into the bag, and refrigerate. Keep checking for mold.

2.2.3 Warm Treatments Before Stratification

A few species of Pacific Northwest evergreens have seed dormancy that is best removed through a combination of warm, moist treatment followed by stratification. Juniper, Pacific yew, western white pine, whitebark pine, and sugar pine are examples of species that often benefit from both treatments. The

requirements and procedures for the warm treatment are basically the same as for stratification except temperatures are increased to around room temperature. Again, seeds should be soaked in running water for 48 hours and then placed either into a plastic bag or between moistened paper towels. Place the bag in a dark area. For pines, a 2- to 4-week period is probably sufficient, but juniper and yew seeds may require 15 to 20 weeks of warmth. (Because of the long warm treatment, bareroot growers should probably sow juniper and yew seeds in late summer or early fall [see Section 3.1.3.2, Sowing and Germination]). Once the warm period is over, seeds are transferred to a refrigerator to complete their stratification. Check often for mold since it can grow rapidly at the warmer temperatures. If your seeds begin to germinate while in the warm treatment, surface dry them until the seed coats are dull, not glossy, and begin stratification.

2.2.4 Moldy Seeds

If mold or damping-off (see sidebar page 13) is a recurring problem with a particular seedlot, you may wish to treat seeds before stratification to remove fungal spores. You may soak seeds in 3% hydrogen peroxide for up to 4 hours, or in a 40% bleach solution for 10 minutes. Mix 2 parts bleach (5.25%

TABLE 2.3

Stratification durations for four common conifers of Idaho, Oregon, and Washington. See Appendix 6.1 for more species.

Common name	Days of stratification
Grand fir	21-42
Colorado (blue) spruce	0-28
Ponderosa pine	30-60
Rocky Mt. Douglas-fir	2-42

Source: Schopmeyer, C.S. 1974. Seeds of Woody Plants in the United States. Agricultural Handbook 450. Washington, D.C.: USDA Forest Service. 883 p. (see Appendix 6.6).

2.2.2 Sandwich Stratification

If you have just a few seeds, this method works well. Stack paper towels about 1/8- to 1/4-inch thick and moisten them completely. Drain off the excess water by holding the towels as shown in Figure 2.15. Place seeds one layer deep on half the paper towel surface and then fold the paper towels over the seeds (Figure 2.16). Put your sandwich into a large, ziplock-type bag

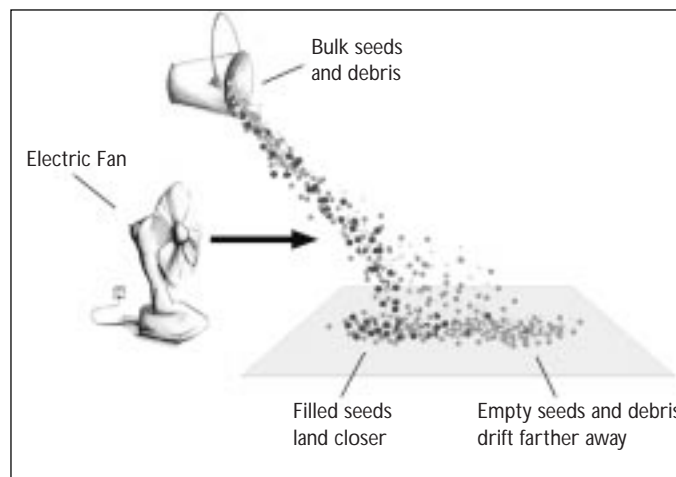

FIGURE 2.10
Use a small fan to winnow unfilled seeds and wings from good, filled seeds. Filled seeds, being heavier, will land closer to the fan while empty seeds and wings, being lighter, will land farther away.

sodium hypochlorite) into 3 parts water for an effective treatment on pines and Douglas-fir. After the chemical soak, rinse seeds with lots of running tap water and then soak for 48 hours in a running water rinse.

If seeds begin to mold during stratification, remove them from stratification and rinse them thoroughly in running tap water to remove the mold. Rehang the bag in a clean plastic bag and return to the refrigerator. You may need to repeat this process often, so keep a watchful eye on your seeds.

2.2.5 Premature Germination

Oh no! You're not ready to sow but you just checked your seeds and a few are beginning to sprout. Remove the seeds from stratification and gently spread them out to surface dry. Allow the surface of the seed coat to dry until it's dull, not glossy. Put the seeds back into a plastic bag and refrigerate—the reduced moisture content will greatly reduce the germination process.

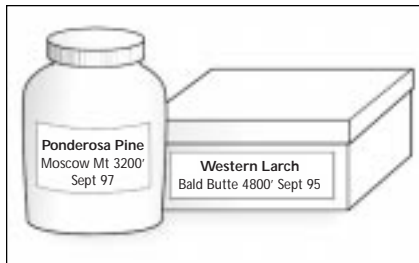

FIGURE 2.12

Store seeds in an airtight container in a freezer or refrigerator. Label the container with the name of the species, collection location, elevation, date collected, and other important information. If you use a cardboard box, put seeds inside a zip-lock-type bag before placing them into the box.



FIGURE 2.11

Cut seeds in half with a pocket knife or safety blade to see if they are filled like the seed in Figure 2.4.

2.2.6 Final Soak

After stratification, remove seeds from the refrigerator and re-soak them in running water for 24 hours. Soaking ensures the seeds have plenty of water to begin the germination process.

2.3 Germination Testing

A germination test will tell you how well your filled seeds will sprout. If you have just a few seeds and plan on growing only a few seedlings for fun, a germination test is unnecessary. However, a germination test will help

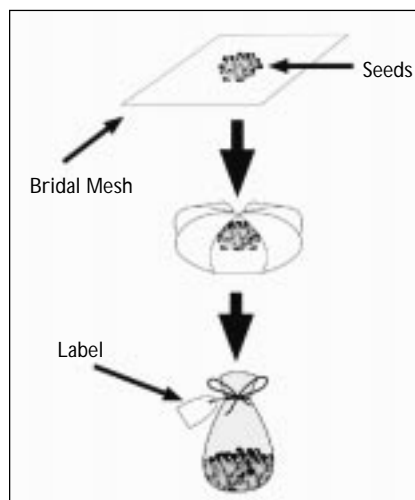

FIGURE 2.13

Use bridal mesh or cheesecloth to form a crude bag to soak and stratify seeds. Start with a square piece, add seeds, fold the corners toward the center and fasten with a twist-tie, making sure there are no holes. Don't forget to label it.

you use seeds efficiently and grow higher-quality seedlings. Germination tests usually start by stratifying seeds. Some species (spruces, some pines, and some cedars), may not require stratification for germination and so you may like to include a non-stratified germination test as well. Plan on using 100 to 400 seeds for each test.

After stratification, rinse seeds in running water for 24 hours. If you test non-stratified seeds, rinse them at the same time, but for 48 hours. Divide the test seeds into four groups. Stack paper towels about 1/8- to 1/4-inch thick and moisten them completely. Drain off the excess water by holding towels as shown

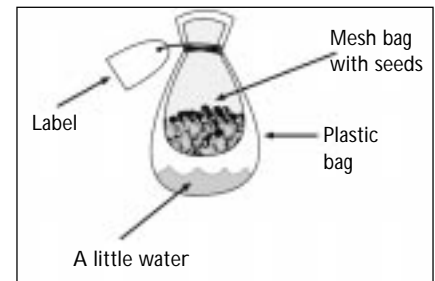

FIGURE 2.14

Soaked seeds hung within a plastic bag and ready for stratification. The bag is tagged for identification. Put a little water in the bottom of the plastic bag to maintain 100% humidity around the seeds, but make sure seeds are not soaking in water.

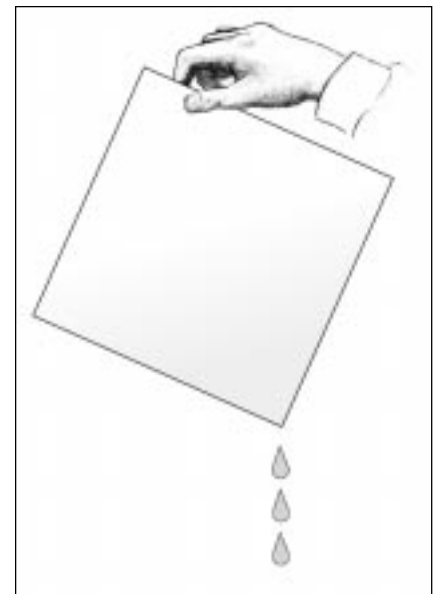

FIGURE 2.15

Hold paper towels by the corner until excess water drips off. Too much water on the towels promotes mold and restricts oxygen movement to seeds.

in Figure 2.15. Put the paper towels into your plastic container and spread seeds over it, maintaining each group. Close the lid and place the container in a location with room temperature and out of direct sunlight. Every five days thereafter, count seeds with primary roots at least as long as the seedcoat, and remove them from the test (Figure 2.18). After 30 days, average the counts from the four groups to get percent germination. Another value you may obtain is germination speed. Germination speed tells how rapidly seeds germinate, and is usually given in days. Of the total number of seeds to germinate, check to see by what day 50% had sprouted. Ideally, most will germinate in the first 10 to 21 days or sooner. If not, your seeds may need a longer cold, moist stratification.

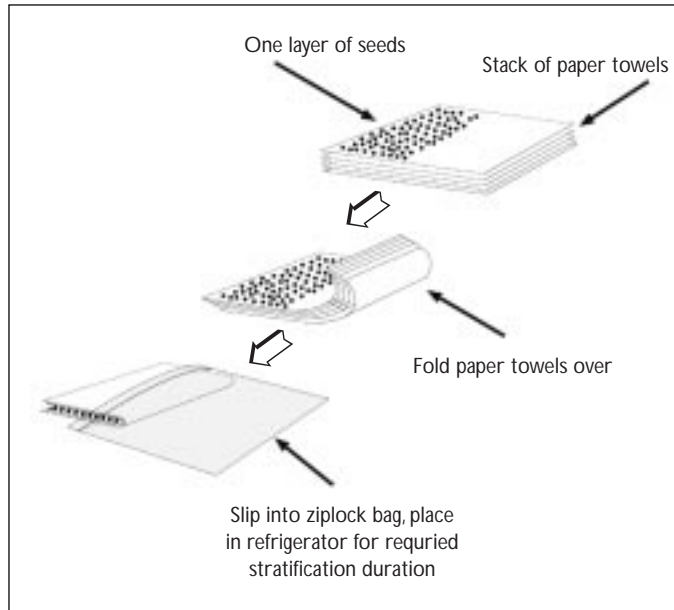

FIGURE 2.16

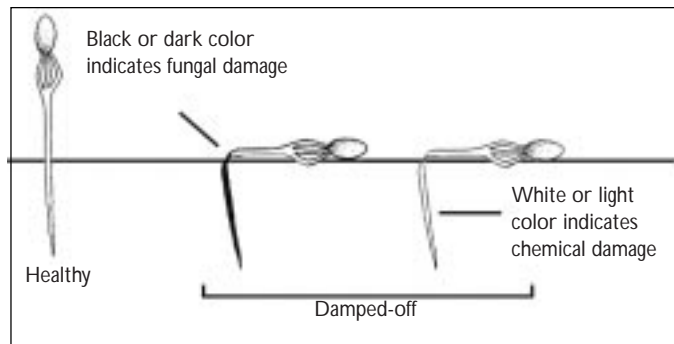

FIGURE 2.17

Typical healthy and damped-off seedlings. Damped-off seedlings usually topple over at the soil surface.

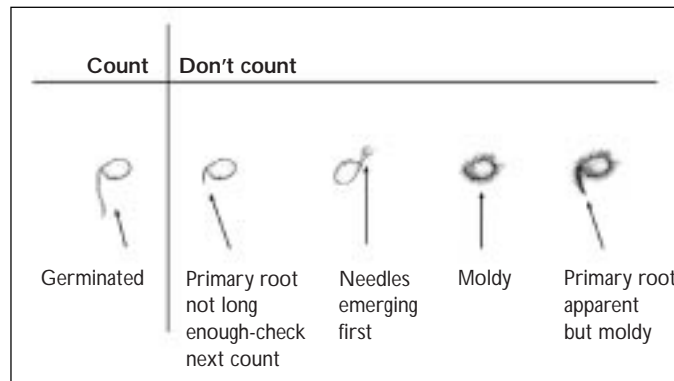

FIGURE 2.18

When checking your germination test, don't count seeds as germinated that have primary roots shorter than one half the length of an individual seed, have needles emerging rather than roots, or are moldy.